

- D** NH-Sicherungslasttrennschalter NH00
- GB** HRC fuse-switch-disconnectors NH00
- F** fusible-interrupteur-sectionneur NH00
- I** Sezionatore portafusibili NH00

D Montageanleitung

GB Installation instruction

F Notice d'instructions

I Istruzioni per il montaggio

- Vor Beginn der Arbeiten Anlagen und Gerät spannungsfrei schalten.
- Sicherungseinsätze und Trennmesser mit versilberten Oberflächen einsetzen.
- Zügig schalten

- Always switch off the power to the systems and equipment before starting your work.
- Utilize silver-coated fuse-links and isolating blades.
- Operate quickly

- Avant le début des travaux, mettre les installations et l'appareil hors tension.
- Veuillez utiliser des fusibles et des couteaux de coupure avec des contacts argentés.
- Mettre en circuit rapidement

- Prima di iniziare il lavoro togliere la tensione dall'impianto e dall'apparecchio.
- Utilizzare fusibili e coltelli divisori con contatti argentati
- Operare rapidamente

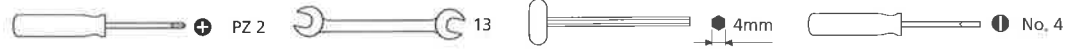

Sammelschienen Montage

Busbar assembly

Montage sur jeu de barres

Montaggio su sbarra collettiva

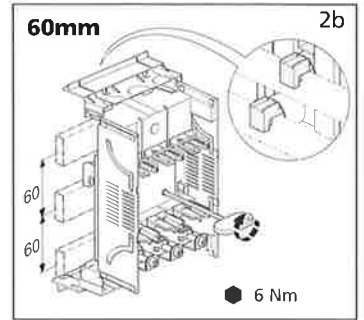
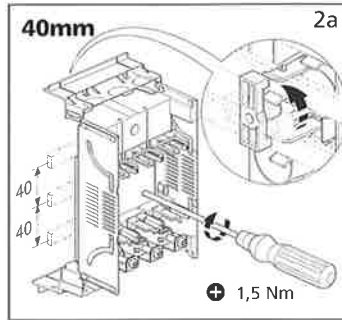
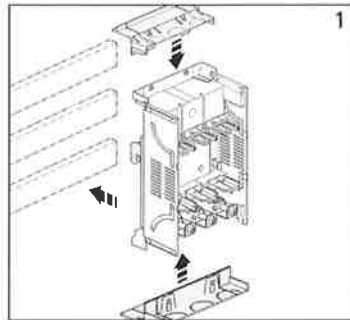

Umbau Abgang unten/oben

Conversion of outgoing bottom/top in no time at all

Changement des départs bas/haut en un tour de main

Trasformazione uscite basso/alto

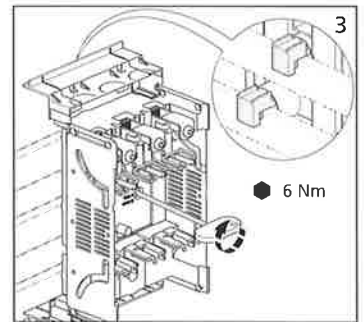
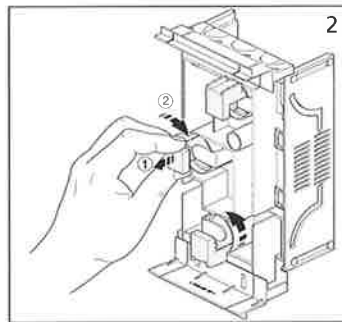
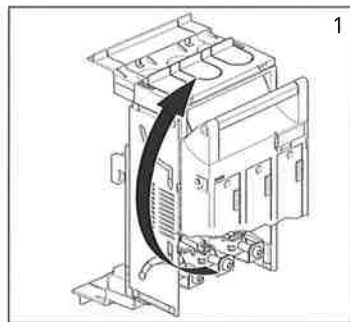

Kabelanschlüsse

Cable connections

Raccords de câbles

Collegamento dei cavi

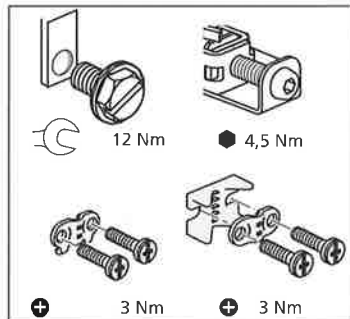

Verriegelung/Plombierung

Locking/sealing facility

Verrouillage/plombage

Blocco/Piombatura

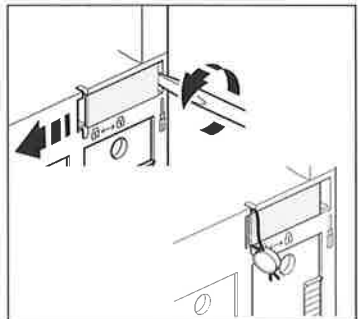

Zubehör

Accessories

Accessoires

Accessori

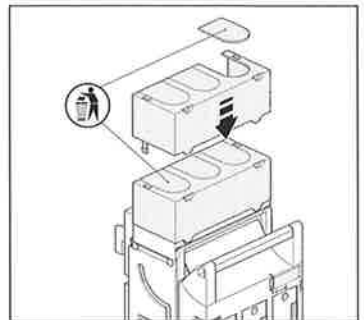
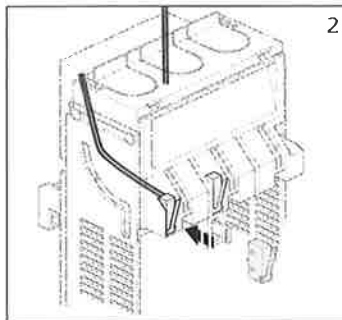
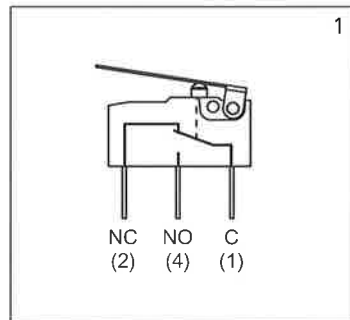

Sicherungsüberwachung

Fuse monitoring

Surveillance des fusibles

Monitoraggio dei fusibili

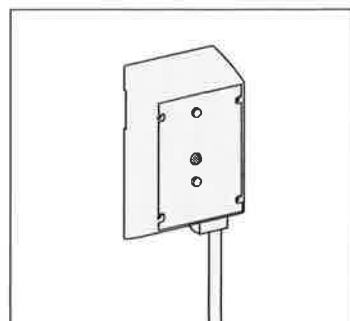

- ⚠ Nur Sicherungseinsätze mit spannungsführenden Griffaschen verwenden!
- Nach Betriebsnahme Prüftaste drücken!
- ⚠ Use only fuse links with metallic alive grip lugs!
- Press test button after startup!

- ⚠ N'utilisez que des cartouches à couteaux avec pattes d'extraction sous tension!
- Après la mise en service, appuyer sur la touche de contrôle!
- ⚠ Utilizzare solo fusibili con alette di estrazione sotto tensione
- Dopo la messa in funzione premere il tasto di controllo!